

精度
±0.005 mm

基本式样 Specification

性能	螺杆等级代号	L		C
	螺杆等级	C7 转造	C7 研磨	C5 研磨
	位置重复精度	± 0.01	±0.005	
	标准行程	50-1250mm / 50间隔	50-700mm / 50间隔	

性能	螺杆导程	mm	5	10	20
	最高转速	rpm	3600	3600	3600
	最高速度	mm/s	300	600	1200
	最大可搬重量	水平使用	kg	50	15
垂直使用		kg	15	8	3
定格推力	N	683	341	174	
最大加速度	G	0.3	0.3	0.6	
滚珠螺杆	基本动额定负荷	N	-	-	-
	基本静额定负荷	N	-	-	-
直线滑轨	动态水平负载	N	-	-	-
	静态水平负载	N	-	-	-
固定侧轴承	基本动额定负荷	N	-	-	-
	静态容许负荷	N	-	-	-
部品	AC伺服马达容量	W	200		
	滚珠螺杆外径	mm	Ø16		
	联轴器	mm	10x14/11		
	原点感应器	外挂	Outside		

*1 马达加减速设定0.2秒。Acceleration and deceleration value is set 0.2 second.
 *2 长行程时，会产生螺杆磨擦，需将速度调降（线速度请参考尺寸图下方表格）。During in a long stroke, it causes ball screw deflection, the speed must reduce. (Please refer to the linear velocity from the data sheet below the dimension graph.)
 *3 使用Panasonic 200W马达时，马达轴心为 Ø11；其他厂牌，马达轴心为 Ø14。Motor (200W) Shaft Diameter: Panasonic: 11mm; Other: 14mm.

容许负载力距表 Allowable Overhang

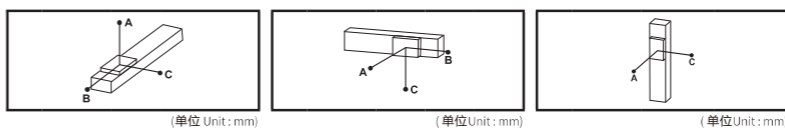

水平安装 Horizontal Installation	重量 Weight	容许力距 Allowable Overhang (mm)		
		A	B	C
导程 5 Lead	20kg	1275	127	197
	30kg	725	72	112
	50kg	380	38	58
导程 10 Lead	10kg	1269	246	345
	20kg	588	104	148
	30kg	352	58	82
导程 20 Lead	5kg	988	380	440
	10kg	471	174	204
	18kg	248	88	104

静额定扭矩 Static Loading Moment

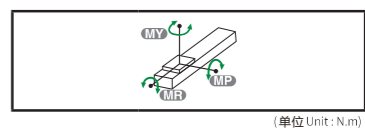

方向 Direction	静额定扭矩 Static Loading Moment (N.m)
MY	318
MP	318
MR	626

*力矩表所表示的数据，代表荷重的重心位置单一方向容许显出的长度。The data represented by the moment table is the center of gravity of the load. The length of the overhang is allowed in a single direction.
 *符合型录规范的正常使用时，保证寿命为10000公里。Operation life is 10,000km when the product is using under the specified conditions.
 *倒吊使用无法套用标准规范，如有需求请咨询我司业务。Data information is not for ceiling-mount inverse use. Contact us for the details if you want to apply ceiling-mount inverse usage.

搭配伺服马达一览表 Suitable Motor Brand

厂牌 Brand	马达记号 Mark	刹车有无 Brake	马达容易 Watt	电源电压 AC-Voltage	伺服马达型号 Motor Model	驱动器型号 Driver Model
三菱 Mitsubishi	M	无刹车 (水平式样) No Brake (Horizontal Type)	200	220	HG-KR23	MR-J4-20A
		有刹车 (垂直式样) With Brake (Vertical Type)	200	220	HG-KR23B	MR-J4-20A
松下 Panasonic	P	无刹车 (水平式样) No Brake (Horizontal Type)	200	220	MHMD022G1U	MADHT1507
		有刹车 (垂直式样) With Brake (Vertical Type)	200	220	MHMD022G1V	MADHT1507
台达 Delta	T	无刹车 (水平式样) No Brake (Horizontal Type)	200	220	ECMA-C20602ES	ASD-B20221-B
		有刹车 (垂直式样) With Brake (Vertical Type)	200	220	ECMA-C20602FS	ASD-B20221-B

最大行程 1250mm
最高速度 1200mm/s
马达容量 200W
最大可搬重量 50kg

型号表示方式 Ordering Method

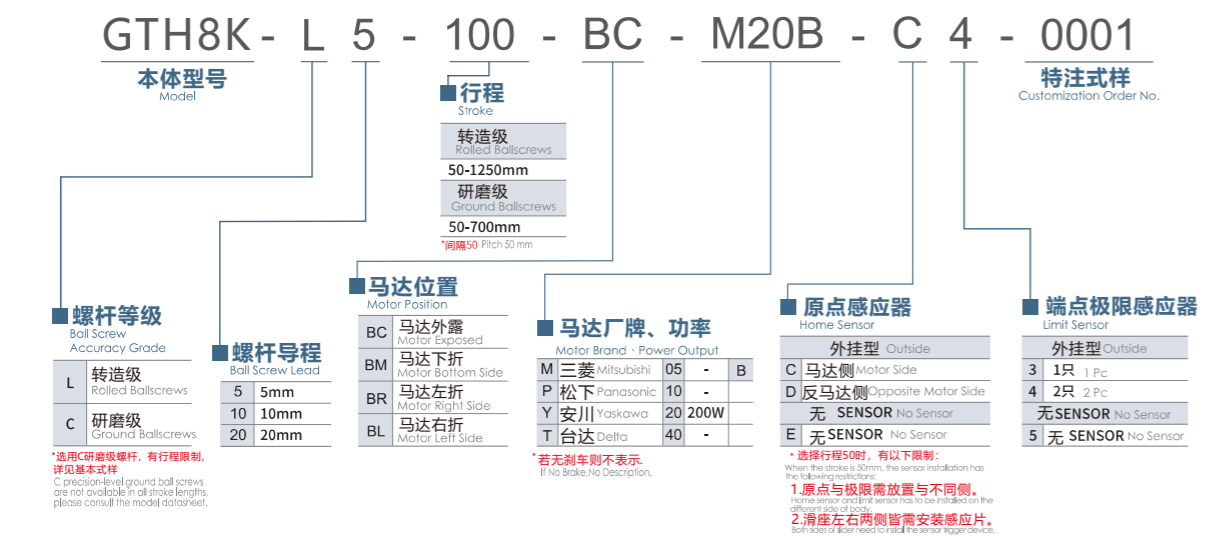

BC 马达外露 Motor Exposed

2D CAD 3D CAD CAD图纸可至www.beartrace.cn下载

单位 Unit: mm

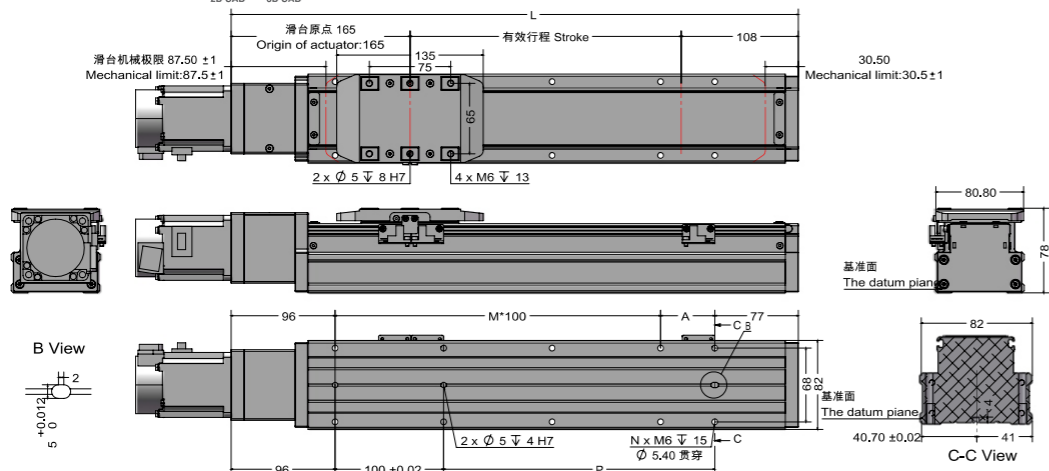

有效行程 Stroke	50 ⁻²	100	150	200	250	300	350	400	450	500	550	600	650	700	750	800	850	900	950	1000	1050	1100	1150	1200	1250	
极限行程 Limit Stroke (±1)	70	120	170	220	270	320	370	420	470	520	570	620	670	720	770	820	870	920	970	1020	1070	1120	1170	1220	1270	
L	323	373	423	473	523	573	623	673	723	773	823	873	923	973	1023	1073	1123	1173	1223	1273	1323	1373	1423	1473	1523	
A	50	100	50	100	50	100	50	100	50	100	50	100	50	100	50	100	50	100	50	100	50	100	50	100	50	
M	1	1	2	2	3	3	4	4	5	5	6	6	7	7	8	8	9	9	10	10	11	11	12	12	13	
N	6	6	8	8	10	10	12	12	14	14	16	16	18	18	20	20	22	22	24	24	26	26	28	28	30	
P	50	100	150	200	250	300	350	400	450	500	550	600	650	700	750	800	850	900	950	1000	1050	1100	1150	1200	1250	
KG	3.91	4.29	4.7	5	5.35	5.68	6	6.35	6.64	6.97	7.41	7.71	8.12	8.41	8.65	8.96	9.37	9.62	10.01	10.28	10.7	11.12	11.54	11.96	12.38	
线速度 Linear Speed mm/s	导程 Lead 5	300																								
	导程 Lead 10	600																								
	导程 Lead 20	1200																								

※2行程50时, 因本体上锁式固定孔会被滑座遮住, 仅能使用4支螺丝固定。建议客户本体用下锁式固定孔锁附。When the stroke is 50mm, if fixing the body from the top to the bottom, the fixing hole will be blocked by slider and only can be uses 4 screws to fix as a result, suggest that fixing actuator body from the bottom to the top.

BL 马达左折 Motor Left Side

2D CAD 3D CAD CAD图纸可至www.beartrace.cn下载

单位 Unit: mm

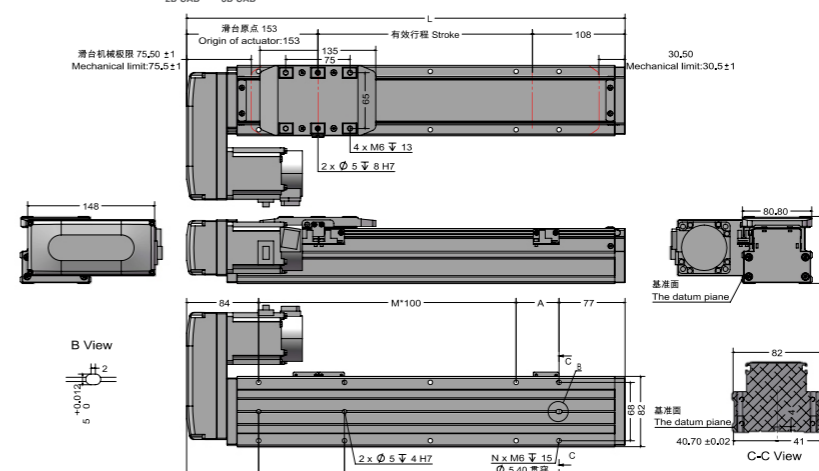

有效行程 Stroke	50 ⁻²	100	150	200	250	300	350	400	450	500	550	600	650	700	750	800	850	900	950	1000	1050	1100	1150	1200	1250	
极限行程 Limit Stroke (±1)	70	120	170	220	270	320	370	420	470	520	570	620	670	720	770	820	870	920	970	1020	1070	1120	1170	1220	1270	
L	311	361	411	461	511	561	611	661	711	761	811	861	911	961	1011	1061	1111	1161	1211	1261	1311	1361	1411	1461	1511	
A	50	100	50	100	50	100	50	100	50	100	50	100	50	100	50	100	50	100	50	100	50	100	50	100	50	
M	1	1	2	2	3	3	4	4	5	5	6	6	7	7	8	8	9	9	10	10	11	11	12	12	13	
N	6	6	8	8	10	10	12	12	14	14	16	16	18	18	20	20	22	22	24	24	26	26	28	28	30	
P	50	100	150	200	250	300	350	400	450	500	550	600	650	700	750	800	850	900	950	1000	1050	1100	1150	1200	1250	
KG	3.95	4.33	4.74	5.09	5.39	5.72	6.04	6.39	6.68	7.01	7.45	7.75	8.16	8.45	8.69	9	9.41	9.66	10.08	10.32	10.74	11.16	11.58	12	12.42	
线速度 Linear Speed mm/s	导程 Lead 5	300																								
	导程 Lead 10	600																								
	导程 Lead 20	1200																								

※2行程50时, 因本体上锁式固定孔会被滑座遮住, 仅能使用4支螺丝固定。建议客户本体用下锁式固定孔锁附。When the stroke is 50mm, if fixing the body from the top to the bottom, the fixing hole will be blocked by slider and only can be uses 4 screws to fix as a result, suggest that fixing actuator body from the bottom to the top.

BM 马达下折 Motor Bottom Side

2D CAD 3D CAD CAD图纸可至www.beartrace.cn下载

单位 Unit: mm

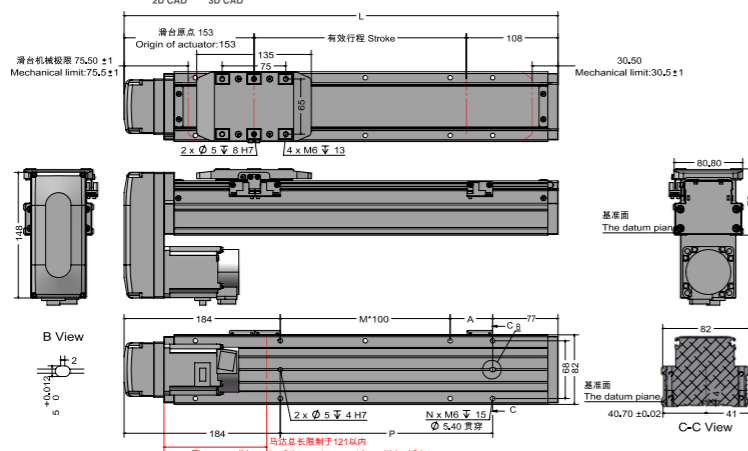

有效行程 Stroke	50 ⁻²	100	150	200	250	300	350	400	450	500	550	600	650	700	750	800	850	900	950	1000	1050	1100	1150	1200	1250	
极限行程 Limit Stroke (±1)	70	120	170	220	270	320	370	420	470	520	570	620	670	720	770	820	870	920	970	1020	1070	1120	1170	1220	1270	
L	311	361	411	461	511	561	611	661	711	761	811	861	911	961	1011	1061	1111	1161	1211	1261	1311	1361	1411	1461	1511	
A	50	100	50	100	50	100	50	100	50	100	50	100	50	100	50	100	50	100	50	100	50	100	50	100	50	
M	0	0	1	1	2	2	3	3	4	4	5	5	6	6	7	7	8	8	9	9	10	10	11	11	12	
N	4	4	6	6	8	8	10	10	12	12	14	14	16	16	18	18	20	20	22	22	24	24	26	26	28	
P	50	100	150	200	250	300	350	400	450	500	550	600	650	700	750	800	850	900	950	1000	1050	1100	1150	1200	1250	
KG	3.95	4.33	4.74	5.09	5.39	5.72	6.04	6.39	6.68	7.01	7.45	7.75	8.16	8.45	8.69	9	9.41	9.66	10.08	10.32	10.74	11.16	11.58	12	12.42	
线速度 Linear Speed mm/s	导程 Lead 5	300																								
	导程 Lead 10	600																								
	导程 Lead 20	1200																								

※1 马达下折时, 若选用刹车马达, 或是超出马达总长度限制时, 无法套用标准PIN孔, 如有需求, 请联系我司业务。When motor with brake assembled on lower side, or the total length over than spec limit, it may not use standard pinhole. Please contact our sales department if you need more information & requirement.
※2 行程50时, 因本体上锁式固定孔会被滑座遮住, 仅能使用4支螺丝固定。建议客户本体用下锁式固定孔锁附。When the stroke is 50mm, if fixing the body from the top to the bottom, the fixing hole will be blocked by slider and only can be uses 4 screws to fix as a result, suggest that fixing actuator body from the bottom to the top.

BR 马达右折 Motor Right Side

2D CAD 3D CAD CAD图纸可至www.beartrace.cn下载

单位 Unit: mm

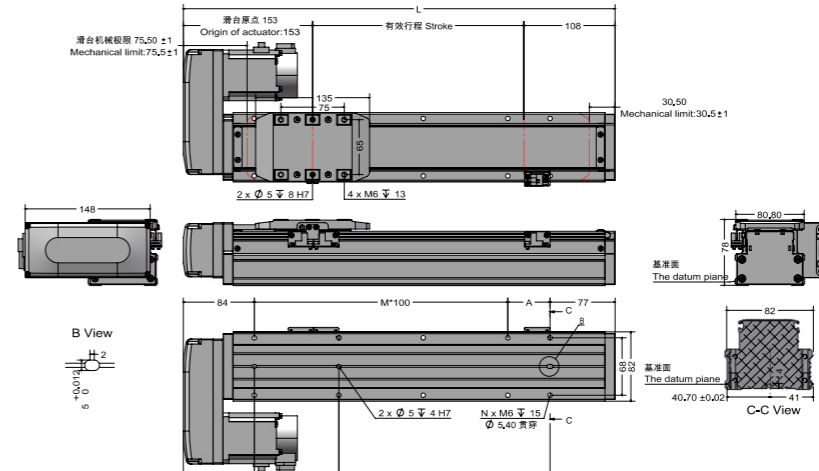

有效行程 Stroke	50 ⁻²	100	150	200	250	300	350	400	450	500	550	600	650	700	750	800	850	900	950	1000	1050	1100	1150	1200	1250	
极限行程 Limit Stroke (±1)	70	120	170	220	270	320	370	420	470	520	570	620	670	720	770	820	870	920	970	1020	1070	1120	1170	1220	1270	
L	311	361	411	461	511	561	611	661	711	761	811	861	911	961	1011	1061	1111	1161	1211	1261	1311	1361	1411	1461	1511	
A	50	100	50	100	50	100	50	100	50	100	50	100	50	100	50	100	50	100	50	100	50	100	50	100	50	
M	1	1	2	2	3	3	4	4	5	5	6	6	7	7	8	8	9	9	10	10	11	11	12	12	13	
N	6	6	8	8	10	10	12	12	14	14	16	16	18	18	20	20	22	22	24	24	26	26	28	28	30	
P	50	100	150	200	250	300	350	400	450	500	550	600	650	700	750	800	850	900	950	1000	1050	1100	1150	1200	1250	
KG	3.95	4.33	4.74	5.09	5.39	5.72	6.04	6.39	6.68	7.01	7.45	7.75	8.16	8.45	8.69	9	9.41	9.66	10.08	10.32	10.74	11.16	11.58	12	12.42	
线速度 Linear Speed mm/s	导程 Lead 5	300																								
	导程 Lead 10	600																								
	导程 Lead 20	1200																								

※2行程50时, 因本体上锁式固定孔会被滑座遮住, 仅能使用4支螺丝固定。建议客户本体用下锁式固定孔锁附。When the stroke is 50mm, if fixing the body from the top to the bottom, the fixing hole will be blocked by slider and only can be uses 4 screws to fix as a result, suggest that fixing actuator body from the bottom to the top.